

ARIZONA DEPARTMENT OF TRANSPORTATION  
205 SOUTH 17TH AVENUE  
R/W Operations, MD 612E  
PHOENIX, AZ 85007-3213

October 19, 2007

RES. NO. 2007-10-A-069  
PROJECT: 600-3-708 / 143MA000H084901R  
600-3-801 / 143MA000H088801R  
HIGHWAY: SKY HARBOR EXPRESSWAY  
SECTION: Washington St. - University Dr.  
ROUTE NO.: State Route 153  
ENG. DIST.: Phoenix  
COUNTY: Maricopa  
DISPOSAL: D-M-400

RESOLUTION OF ABANDONMENT

VICTOR M. MENDEZ, Director, Arizona Department of Transportation, on October 19, 2007, presented and filed with this Transportation Board his written report under Arizona Revised Statutes Section 28-7046, recommending the abandonment of State Route 153 in its entirety within the above referenced projects.

The right of way to be abandoned is depicted in Appendix "A" and delineated on maps and plans on file in the office of the State Engineer, Intermodal Transportation Division, Phoenix, Arizona, entitled "Right of Way Plans, SKY HARBOR EXPRESSWAY, Projects 600-3-708 / 143MA000H084901R and 600-3-801 / 143MA000H088801R."

WHEREAS said right of way is no longer needed for state transportation purposes; and

WHEREAS the City of Phoenix has agreed to accept the constructed portion of State Route 153 in its entirety; and

WHEREAS this Board finds that public safety, necessity and convenience will be served by accepting the Director's report; therefore, be it

RESOLVED that the recommendation of the Director is adopted and made part of this resolution; be it further

October 19, 2007

RES. NO. 2007-10-A-069  
PROJECT: 600-3-708 / 143MA000H084901R  
600-3-801 / 143MA000H088801R  
HIGHWAY: SKY HARBOR EXPRESSWAY  
SECTION: Washington St. - University Dr.  
ROUTE NO.: State Route 153  
ENG. DIST.: Phoenix  
COUNTY: Maricopa  
DISPOSAL: D-M-400

RESOLVED that the right of way depicted in Appendix "A" is hereby removed from the State Highway System and abandoned to The City of Phoenix as provided in Arizona Revised Statute Section 28-7207 and 28-7209, and effective upon recordation in the Office of the County Recorder in accordance with Arizona Revised Statute Section 28-7213; be it further

RESOLVED that the Director provide written notice to The City of Phoenix evidencing the abandonment of the State's interest.

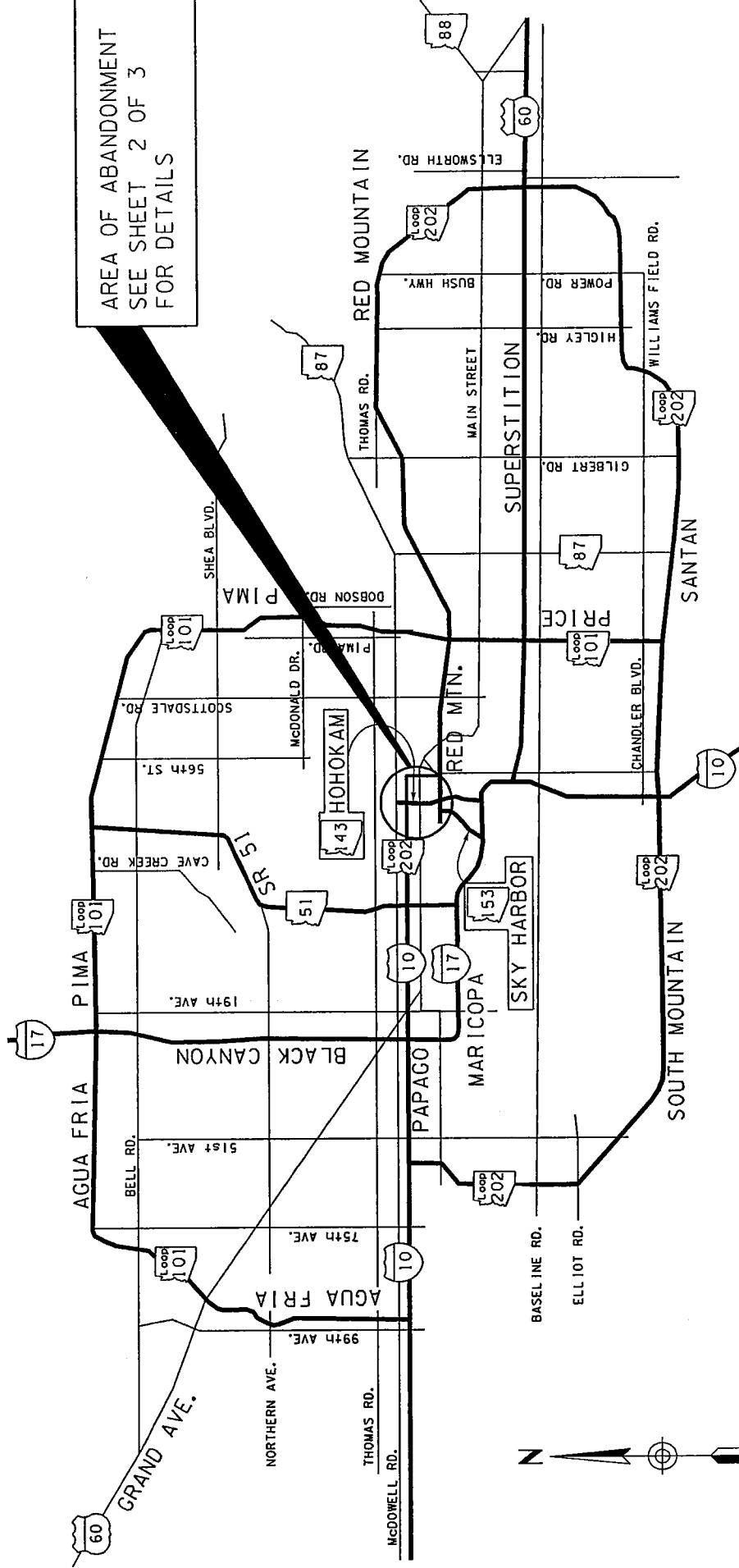

AREA OF ABANDONMENT  
SEE SHEET 2 OF 3  
FOR DETAILS

SKY HARBOR EXPRESSWAY  
143 MA 000 H0849 OIR / 600-3-7000  
143 MA 000 H0888 OIR / 600-3-8000  
Washington St - University Dr  
Maricopa County

DATE: OCT 19, 2007 SHEET 1 OF 3

**APPENDIX "A"**

THIS PLAT WAS DIGITALLY PRODUCED  
FROM ARIZONA DEPARTMENT OF  
TRANSPORTATION  
GENERAL HIGHWAY MAP

RIGHT OF WAY PLANS SECTION  
REVISED MAY 17, 2000

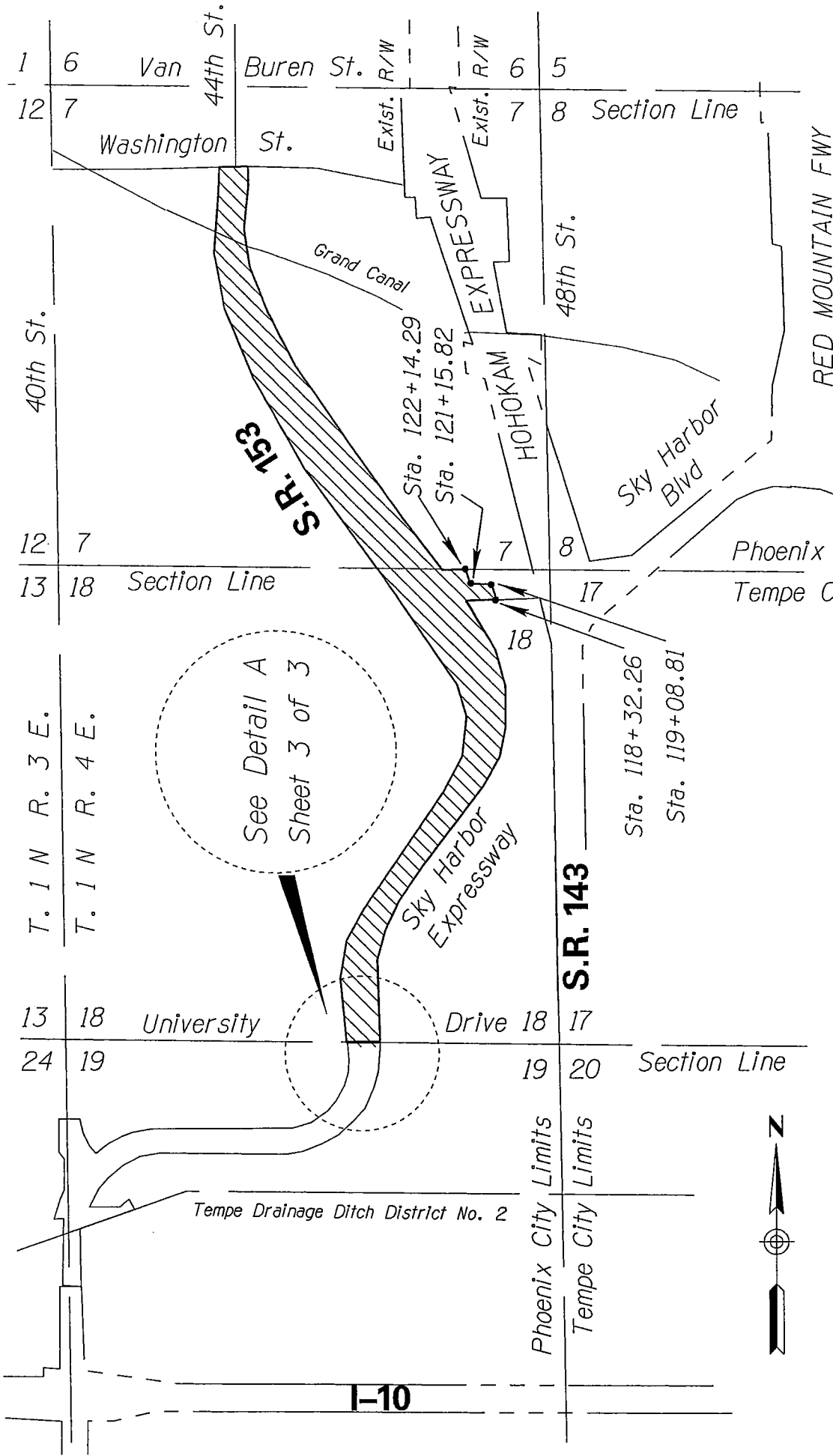

**S.R. 153**

**S.R. 143**

See Detail A  
Sheet 3 of 3

SKY HARBOR EXPRESSWAY  
 143 MA 000 H0849 OIR / 600-3-708  
 143 MA 000 H0888 OIR / 600-3-801  
 Washington St - University Dr  
 Maricopa County

DATE: OCT 19, 2007 SHEET 2 OF 3

AREA OF  
 ABANDONMENT

**APPENDIX "A"**

THIS PLAT WAS DIGITALLY PRODUCED  
 FROM ARIZONA DEPARTMENT OF  
 TRANSPORTATION  
 GENERAL HIGHWAY MAP

RIGHT OF WAY PLANS SECTION  
 REVISED JULY 17, 2000

T. 1 N R. 3 E.  
T. 1 N R. 4 E.

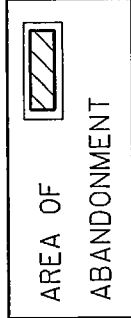
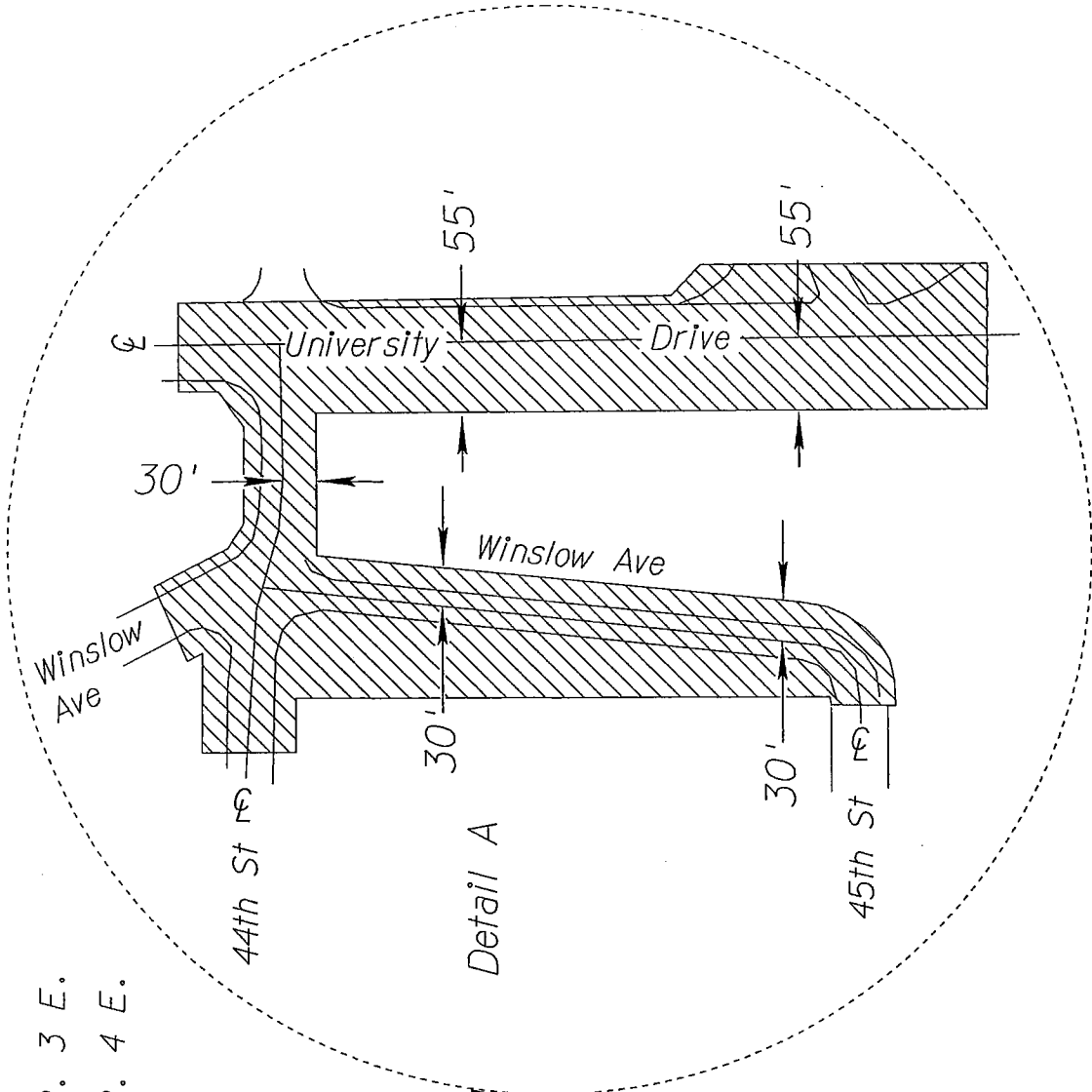
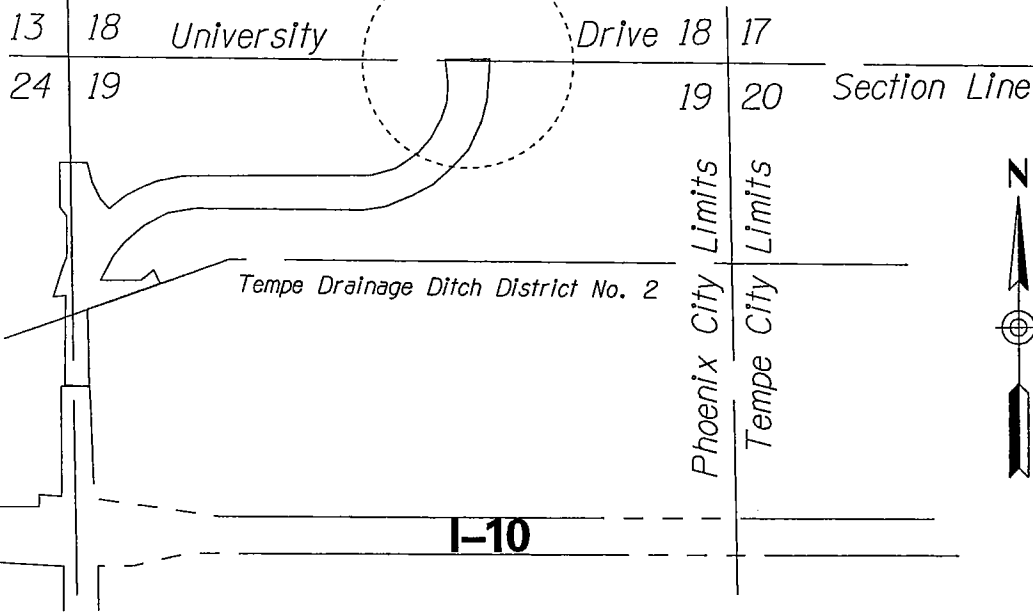

**APPENDIX "A"**

THIS PLAT WAS DIGITALLY PRODUCED FROM ARIZONA DEPARTMENT OF TRANSPORTATION GENERAL HIGHWAY MAP

RIGHT OF WAY PLANS SECTION REVISED JULY 17, 2000

SKY HARBOR EXPRESSWAY  
143 MA 000 H0849 OIR / 600-3-700  
143 MA 000 H0888 OIR / 600-3-800  
Washington St - University Dr  
Maricopa County

October 19, 2007

RES. NO. 2007-10-A-069  
PROJECT: 600-3-708 / 143MA000H084901R  
600-3-801 / 143MA000H088801R  
HIGHWAY: SKY HARBOR EXPRESSWAY  
SECTION: Washington St. - University Dr.  
ROUTE NO.: State Route 153  
ENG. DIST.: Phoenix  
COUNTY: Maricopa  
DISPOSAL: D-M-400

REPORT AND RECOMMENDATION

TO THE HONORABLE ARIZONA TRANSPORTATION BOARD:

The Intermodal Transportation Division has made a thorough investigation concerning the abandonment of State Route 153 in its entirety within the above referenced project.

State Route 153 was previously established as a Preliminary Transportation Corridor by Arizona Transportation Board Resolution 85-04-A-38, dated April 26, 1985. Subsequent Resolutions authorized construction of improvements as a state highway for public safety and necessity.

The constructed right of way for State Route 153 is no longer needed for state transportation purposes. The City of Phoenix has agreed to accept jurisdiction of the constructed right of way. Accordingly, I recommend that the State's interest in the right of way be abandoned.

The right of way to be abandoned is depicted in Appendix "A" and delineated on the maps and plans on file in the office of the State Engineer, Intermodal Transportation Division, Phoenix, Arizona, entitled "Right of Way Plans, SKY HARBOR EXPRESSWAY, Projects 600-3-708 / 143MA000H084901R and 600-3-801 / 143MA000H088801R."

I further recommend that the right of way depicted in Appendix "A" be removed from the State Highway System and abandoned to The City of Phoenix for a continued public transportation facility.

October 19, 2007

RES. NO. 2007-10-A-069  
PROJECT: 600-3-708 / 143MA000H084901R  
600-3-801 / 143MA000H088801R  
HIGHWAY: SKY HARBOR EXPRESSWAY  
SECTION: Washington St. - University Dr.  
ROUTE NO.: State Route 153  
ENG. DIST.: Phoenix  
COUNTY: Maricopa  
DISPOSAL: D-M-400

All other rights of way and easements and appurtenances thereto subject to the provisions of Arizona Revised Statutes Section 28-7210 shall continue as they existed prior to the disposal of right of way depicted in Appendix "A".

Pursuant to Arizona Revised Statutes Section 28-7046, I recommend that the Transportation Board adopt a resolution making this recommendation effective.

Respectfully submitted,



VICTOR M. MENDEZ, Director  
Arizona Department of Transportation

October 19, 2007

RES. NO. 2007-10-A-069  
PROJECT: 600-3-708 / 143MA000H084901R  
600-3-801 / 143MA000H088801R  
HIGHWAY: SKY HARBOR EXPRESSWAY  
SECTION: Washington St. - University Dr.  
ROUTE NO.: State Route 153  
ENG. DIST.: Phoenix  
COUNTY: Maricopa  
DISPOSAL: D-M-400

CERTIFICATION

I, VICTOR M. MENDEZ, Director of the Arizona Department of Transportation, do hereby certify that the foregoing is a true and correct copy from the minutes of the Transportation Board made in official session on October 19, 2007.

IN WITNESS WHEREOF I have hereunto set my hand and the official seal of the Transportation Board on October 19, 2007.

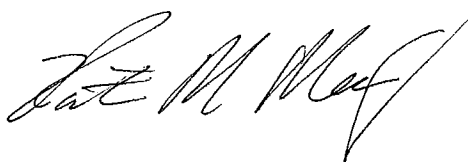

VICTOR M. MENDEZ, Director  
Arizona Department of Transportation